

NOTES:

1. ALL DIMENSIONS FOR REFERENCE ONLY
2. TUBE RETENTION PRESSURE SUBJECT TO TUBING DIMENSION AND STIFFNESS

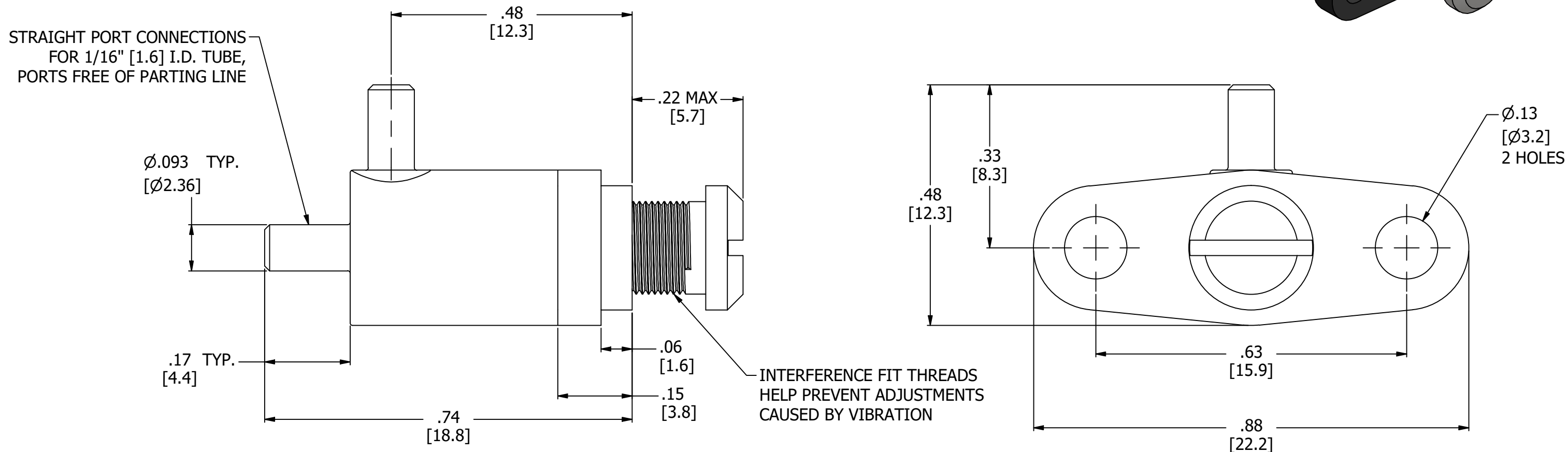
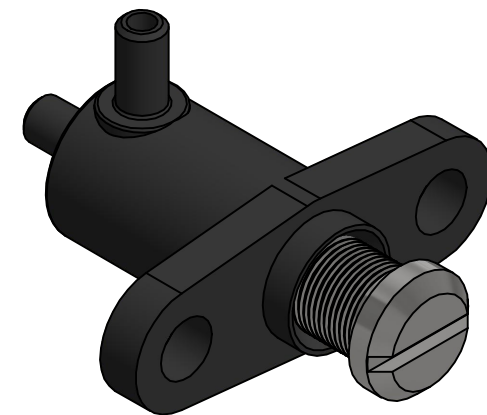

PRODUCT SPECIFICATIONS

COLOR(S)	BLACK, STAINLESS STEEL
ADJUSTMENT METHOD	SCREWDRIVER ADJUSTED
THREAD PITCH	64 TPI.
FLOW COEFFICIENT (Cv)	0.0000133 - .0195
MEDIA	GASES, LIQUIDS
MAX INLET PRESSURE	125 PSI, [8.6 BAR]
TYPICAL TUBE RETENTION PRESSURE	25 PSI, [1.7 BAR], NOTE 2
MOUNTING STYLE	PANEL MOUNT
WETTED MATERIALS	NYLON, STAINLESS STEEL, BUNA-N
RECOMMENDED SYSTEM FILTRATION	5 MICRON



AIR-LOGIC @ DIVISION OF KNAPP MFG, INC.
 5102 DOUGLAS AVE RACINE, WI 53402
 PHONE: (262) 639-9035 FAX: (262) 639-5996 WEB: AIR-LOGIC.COM

PART/DRAWING NO.:

F282241SS

DESCRIPTION:
 PLASTIC NEEDLE VALVE, #10-64, PANEL MOUNT, 1/16"
 STRAIGHT PORTS, SCREWDRIVER ADJUST

REVISION: A	DRAWN: 2/24/2021
SCALE: 5 : 1	SHEET SIZE: B

TERMS OF USE:
 THIS DRAWING IS FOR INFORMATIONAL PURPOSES ONLY. AIR LOGIC MAKES NO REPRESENTATIONS OF WARRANTIES CONCERNING SUITABILITY FOR ANY PARTICULAR PURPOSE. ALL PRODUCTS SUPPLIED ARE SUBJECT TO TERMS AND CONDITIONS FOUND AT AIR-LOGIC.COM

DRAWING TAKES PRECEDENCE OVER 3D MODEL GEOMETRY
 TOLERANCE: DECIMALS .00 ± .01, .000 ± .005, FRACTIONS ± 1/64
 ANGLES 1/4° UNLESS OTHERWISE SPECIFIED
 UNITS: INCHES [MILLIMETERS]