

NOTES:

1. ALL DIMENSIONS FOR REFERENCE ONLY
2. TUBE RETENTION PRESSURE SUBJECT TO TUBING DIMENSION AND STIFFNESS

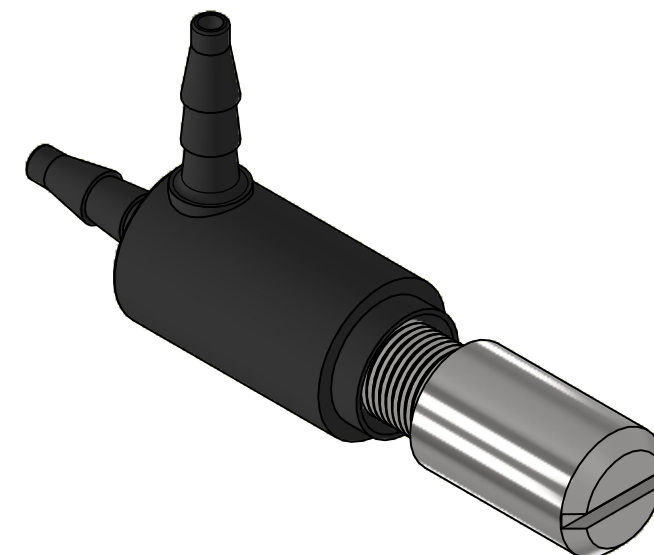
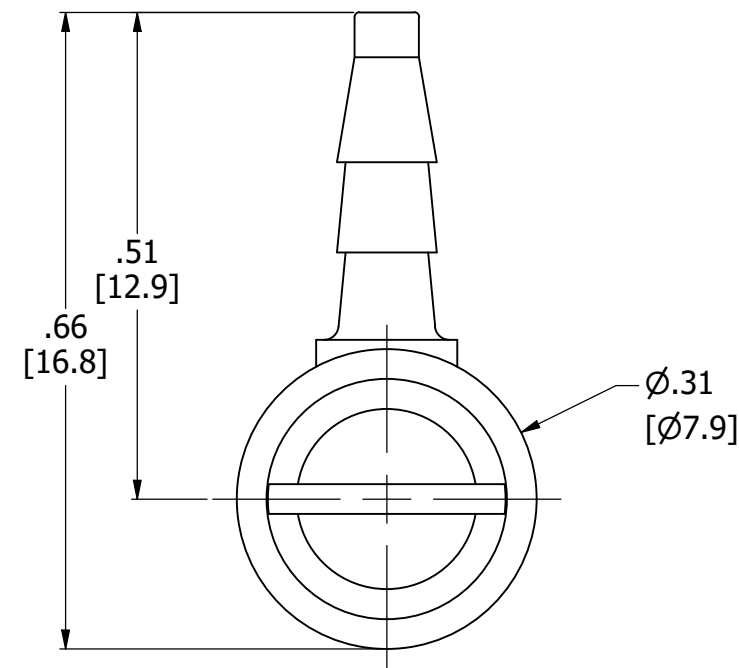
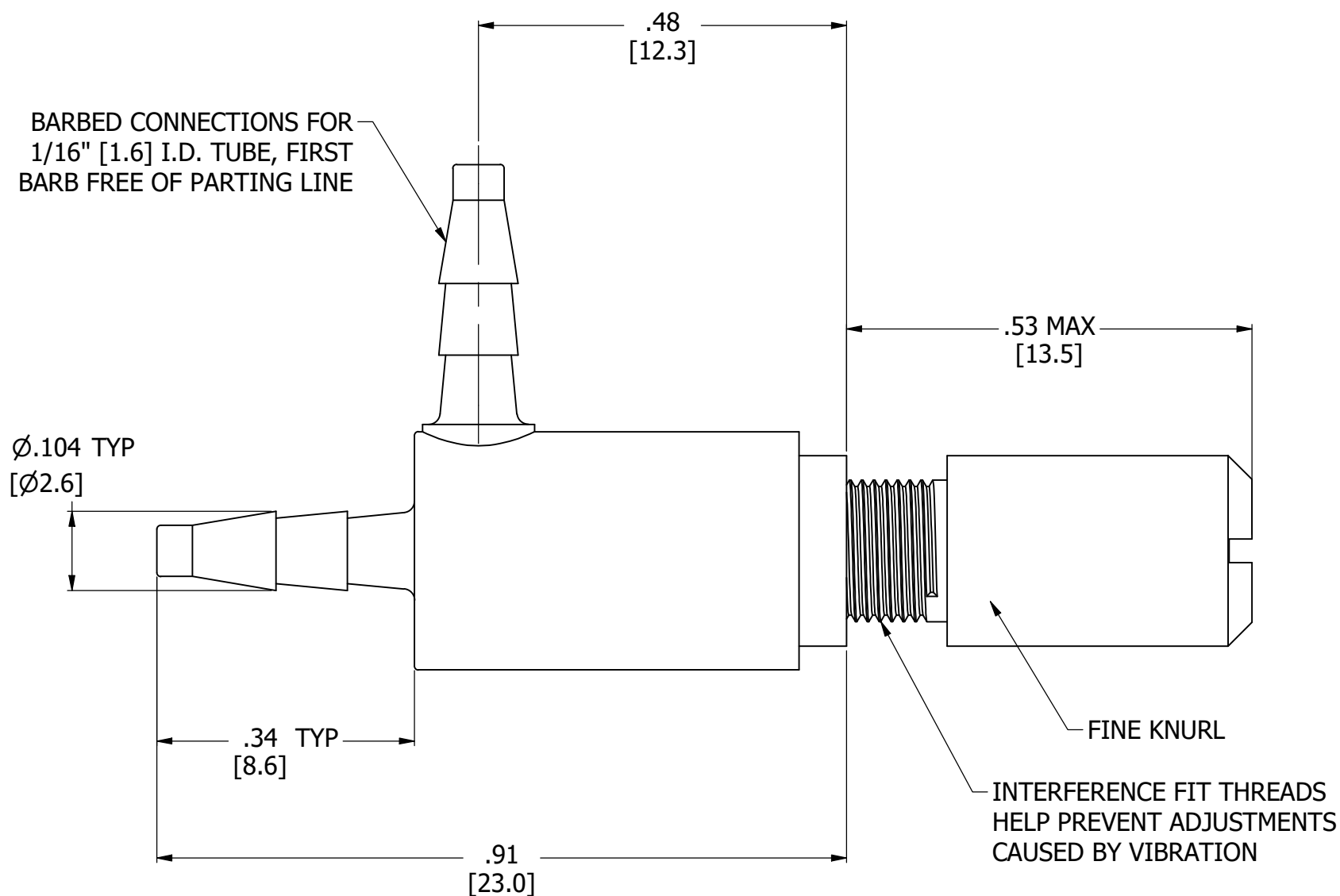

PRODUCT SPECIFICATIONS

COLOR(S)	BLACK, STAINLESS STEEL
ADJUSTMENT METHODS	FINGER/SCREWDRIVER ADJUSTED
THREAD PITCH	64 TPI.
FLOW COEFFICIENT (Cv)	0.0000133 - .0195
MEDIA	GASES, LIQUIDS
MAX INLET PRESSURE	125 PSI [8.6 BAR]
TYPICAL TUBE RETENTION PRESSURE	125 PSI [8.6 BAR], NOTE 2
MOUNTING STYLE	INLINE
WETTED MATERIALS	NYLON, STAINLESS STEEL, EDPM
RECOMMENDED SYSTEM FILTRATION	5 MICRON



AIR-LOGIC

5102 DOUGLAS AVE RACINE, WI 53402
 PHONE: (262) 639-9035 FAX: (262) 639-5996 WEB: AIR-LOGIC.COM

PART/DRAWING NO.:

F282240B80KSSWSE

DESCRIPTION:

PLASTIC NEEDLE VALVE, #10-64, 1/16 INCH BARBS, EPDM O-RING, KNOB W/ SLOT

REVISION: A

DRAWN: 7/1/2022

SCALE: 5 : 1

SHEET SIZE: B

TERMS OF USE:

THIS DRAWING IS FOR INFORMATIONAL PURPOSES ONLY. AIR LOGIC MAKES NO REPRESENTATIONS OF WARRANTIES CONCERNING SUITABILITY FOR ANY PARTICULAR PURPOSE. ALL PRODUCTS SUPPLIED ARE SUBJECT TO TERMS AND CONDITIONS FOUND AT AIR-LOGIC.COM

DRAWING TAKES PRECEDENCE OVER 3D MODEL GEOMETRY

TOLERANCE: DECIMALS .00 ± .01, .000 ± .005, FRACTIONS ± 1/64
 ANGLES 1/4° UNLESS OTHERWISE SPECIFIED
 UNITS: INCHES [MILLIMETERS]